

111-006-10R

- ◆ With round depth bar, for small hole depth measurement
- ◆ Resolution: 0.01mm/0.0005"
- ◆ Buttons: on/off, zero, mm/in, ABS
- ◆ Data output(cable code: 100-03 or 100-04)
- ◆ Automatic power on/off
- ◆ Meet DIN862
- ◆ Made of stainless steel

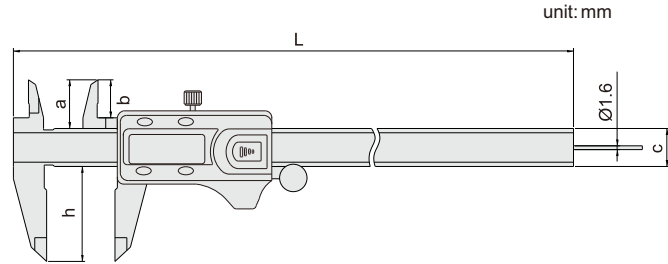

unit: mm

Round depth bar

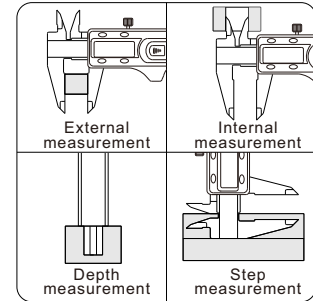
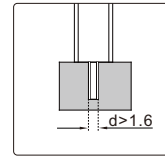

Code	Range	Accuracy	Thumb roller	a	b	c	h	L
111-006-10R	0-150mm/0-6"	±0.03mm	with	21	16	16	40	236
111-006-10RW	0-150mm/0-6"	±0.03mm	without	21	16	16	40	236

With manufacturer inspection certificate