

- ◆ Supplied with 3 pairs of points and one zero setting block for external measurement
- ◆ Resolution: 0.01mm/0.0005"
- ◆ Buttons: on/off, zero, mm/inch
- ◆ Automatic power on/off
- ◆ Data output (cable code: 100-11 or 100-12)
- ◆ Made of stainless steel

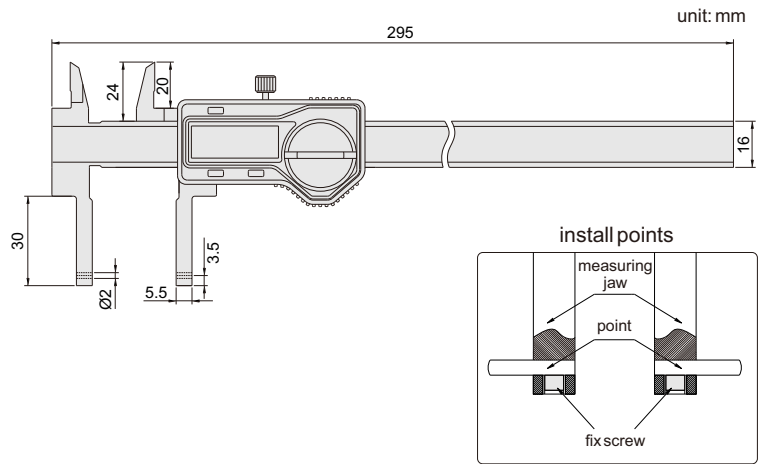

short spherical points (included)

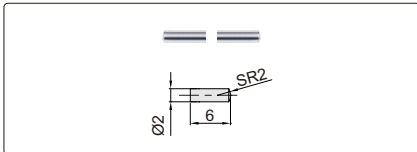

long spherical/flat points (included)

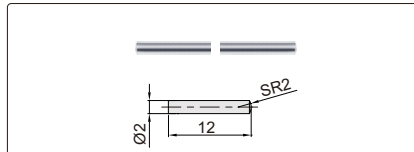

short spherical blade points (included)

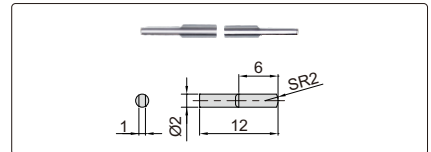

zero setting block for external measurement (included)



Measure internal and external grooves

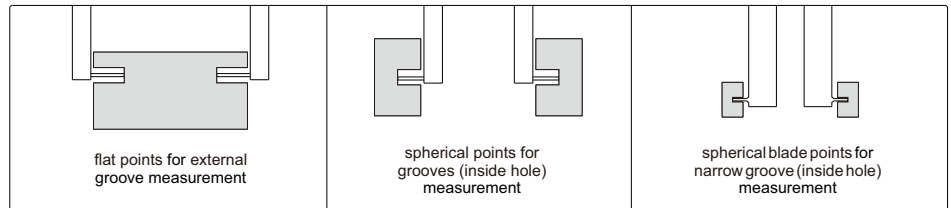

Code	Point	Range	Accuracy	Application
149-008-11	short spherical points	12-212mm/0.5-8.5"(internal)	±0.03mm	for grooves/inside small hole
	long spherical/flat points	24-224mm/1-8.8"(internal) 0-187mm/0-7.5"(external)	±0.03mm	spherical points for grooves/inside hole, flat points for external grooves
	spherical blade points	24-224mm/1-8.8"(internal) 0-187mm/0-7.5"(external)	±0.03mm	for narrow grooves/inside hole