

SERIES 156

DIGITAL GEAR TOOTH CALIPER



ACCUD



CALIPER

- ◆ Resolution: 0.01mm/0.0005"
- ◆ Buttons: on/off, zero, mm/inch
- ◆ Made of stainless steel

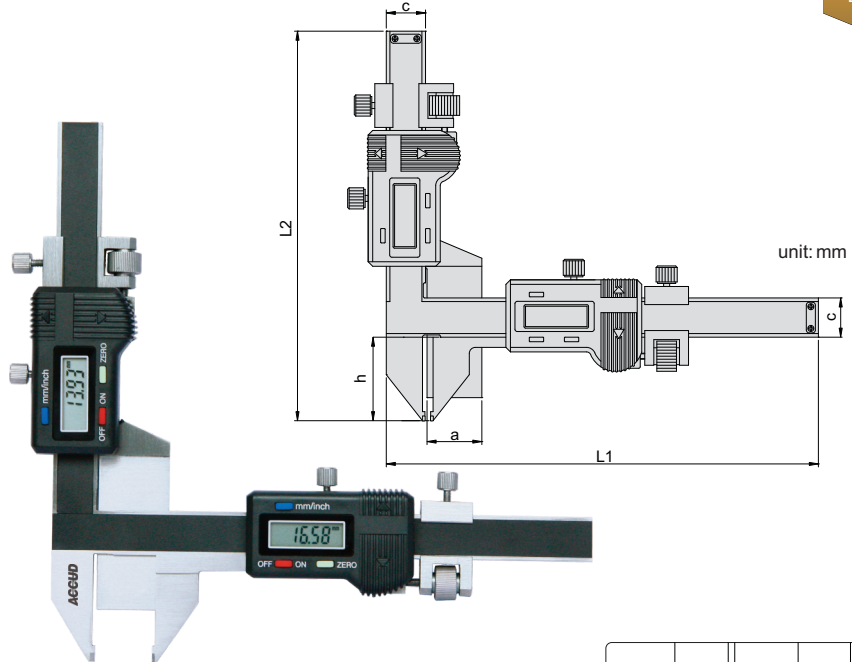

156-001-11

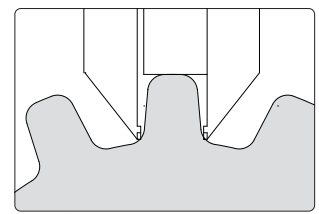

Code	Range	Accuracy	L1	L2	a	c	h
156-001-11	M1-25mm	±0.04mm	170	156	12.5	13	32
156-002-11	M5-50mm	±0.04mm	220	190	50.5	16	55