

**176**

## VERNIER DEPTH CALIPER

- ◆ Measure the depth of grooves, small holes and tire thread
- ◆ Graduation: 0.1mm
- ◆ Made of stainless steel

Set zero

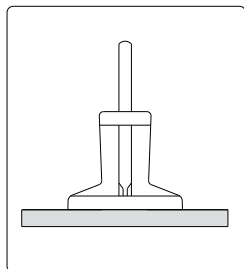

Measure

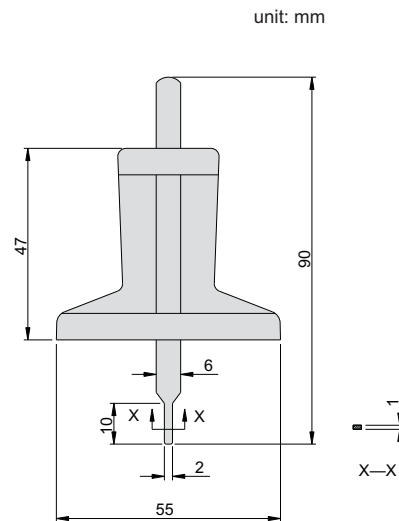
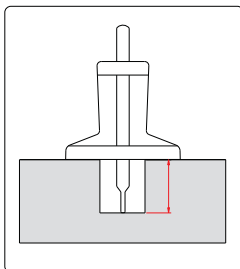

**Code**

**176-030-12**

**Range**

0-30mm

**Accuracy**

±0.10mm