



SERIES 249

BORE GAGE FOR BLIND HOLES

- ◆ To measure diameter of shallow and blind holes
- ◆ Optional accessory:
 - 0.01mm or 0.001mm graduation dial indicators (222-010-12 or 222-001-02);
 - digital indicator (215-010-11 or 215-010-12);
 - setting ring (series 531);
 - bore gauge setter(255-016-11)

Bore gauge setter for setting zero **(optional)**

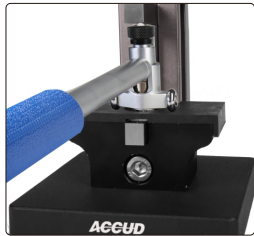

Setting ring **(optional)**



Measuring tips **(included)**

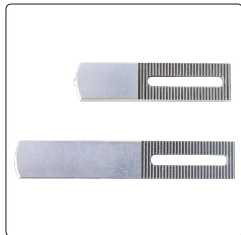

Digital indicator **(optional)**



249-110-51

dial indicator is not included

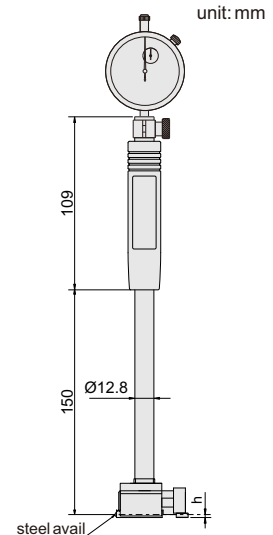

Range: 50-110mm

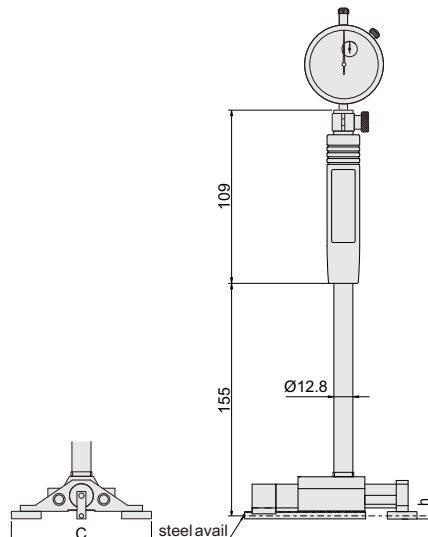

Range: 110-300mm

| Code | Range | Accuracy (without dial indicator) | Repeatability (without dial indicator) | C | h |
|------------|-----------|-----------------------------------|--|----|---|
| 249-110-51 | 50-110mm | 4µm | 1µm | 37 | 2 |
| 249-300-51 | 110-300mm | 4µm | 1µm | 94 | 2 |