

## SERIES 252 INCH DIAL BORE GAUGE

◆ Optional accessory: Long handle series 250

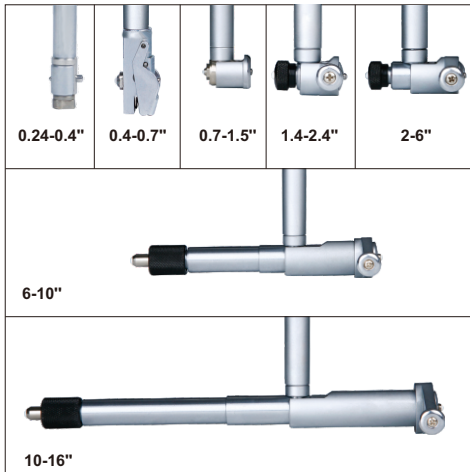

252-015-11

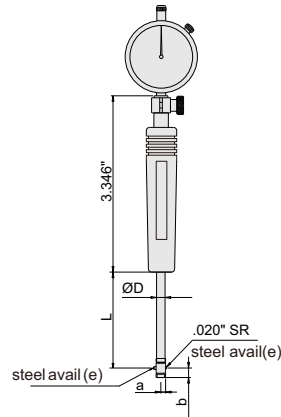

Range: .24-0.4"

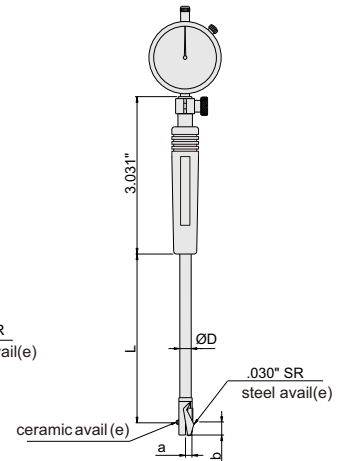

Range: .4-0.7"

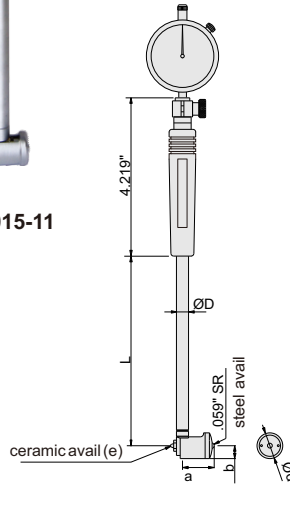

Range: .7-1.5"

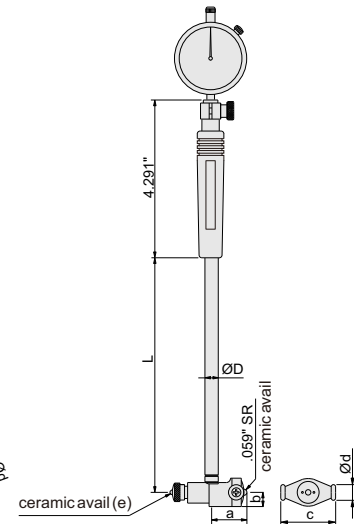

Range: 1.4-16"

Bore gauge setter for setting zero (optional)



Setting ring (optional)



Measuring tips (included)



Gasket (included)



INSIDE/OUTSIDE MEASUREMENT

Code	Range	Dial indicator	Accuracy	Repeatability	a	b	c	Ød	ØD	e	L
252-004-11	0.24-0.4"	dial indicator, range .25", graduation .0005"	±.00075"	.00015"	.142"	.224"	/	/	.177"	.039" R	1.890"
252-007-11	0.4-0.7"		±.00075"	.00015"	.220"	.307"	/	/	.236"	.039" SR	4.134"
252-015-11	0.7-1.5"		±.00075"	.00015"	.480"	.252"	/	.5"	.354"	.039" SR	5.551"
252-024-11	1.4-2.4"		±.0009"	.00015"	1.024"	.354"	1.063"	.512"	.504"	.079" SR	5.551"
252-060-11	2-6"		±.0009"	.00015"	1.024"	.354"	1.378"	.512"	.504"	.079" SR	5.551"
252-100-11	6-10"		±.0009"	.00015"	2.224"	.512"	2.933"	.591"	.571"	.079" SR	15.748"
252-160-11	10-16"		±.0009"	.00015"	3.406"	.591"	3.996"	.591"	.571"	.079" SR	15.748"