



- ◆ Can be used in vertical and horizontal
- ◆ To be used with gauge blocks

Gauge block set (grade 2,ISO3650) for 256-160-11

Blocks per set	Size(mm)	Step(mm)	Quantity(pcs)
33	1.005	—	1
	1.01-1.09	0.01	9
	1.1-1.9	0.1	9
	1-9	1	9
	10-30	10	3
	50	—	1
	100	—	1

Code	Range	Repeatability	Gauge block set
256-160-11*	0-160mm	1.2μm	with
256-160-10	0-160mm	1.2μm	without

* with calibration certificate

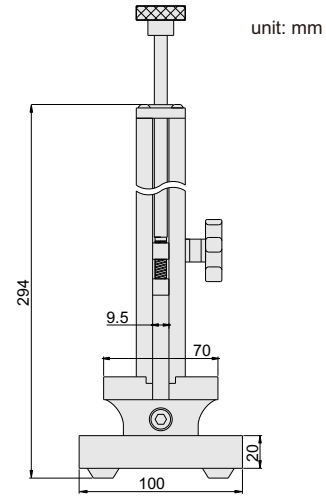

INSIDE/OUTSIDE MEASUREMENT

Application



Gauge block set for 256-160-11

