

SERIES 325

OUTSIDE MICROMETER WITH INTERCHANGEABLE ANVILS

- ◆ Graduation: 0.01mm
- ◆ Ratchet stop
- ◆ Carbide measuring faces
- ◆ Supplied with setting standards



325-006-01

unit: mm

Setting standards (included)



interchangeable anvils (included)

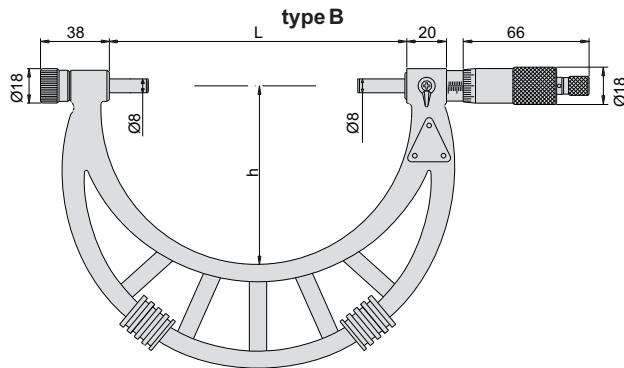
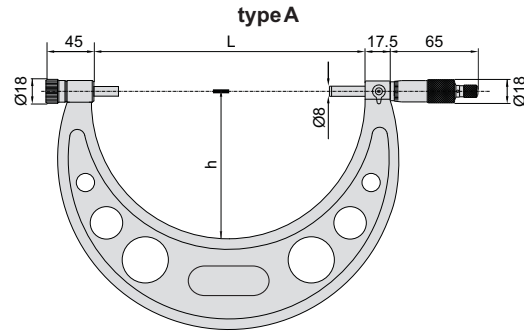
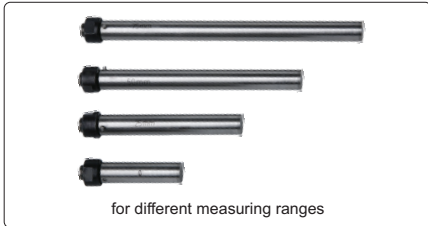

Code	Range	Type	Accuracy	L	h	Setting standards(included)
325-002-01	0-50mm	A	4µm	58	35	25mm
325-004-01	0-100mm	A	5µm	108	57	25,50,75mm
325-006-01	0-150mm	A	6µm	158	82	25,50,75,100,125mm
325-008-01	100-200mm	A	7µm	208	114	100,125,150,175mm
325-012-01	150-300mm	A	9µm	308	165	150,175,200,225,250,275mm
325-006-02	50-150mm	A	6µm	158	82	50,75,100,125mm
325-012-02	200-300mm	A	9µm	308	165	200,225,250,275mm
325-016-02	300-400mm	B	11µm	409	224	325,375mm
325-020-02	400-500mm	B	13µm	509	275	425,475mm
325-024-02	500-600mm	B	14µm	609	321	525,575mm
325-028-02	600-700mm	B	16µm	709	371	625,675mm
325-032-02	700-800mm	B	18µm	809	426	725,775mm
325-036-02	800-900mm	B	20µm	909	476	825,875mm
325-040-02	900-1000mm	B	22µm	1009	576	925,975mm