

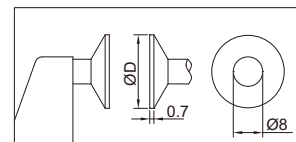

- ◆ Measure root tangent length of gear
- ◆ Resolution 0.001mm/0.00005"
- ◆ Non-rotating spindle
- ◆ Button: on/off, set, mm/inch, ABS/INC, data output
- ◆ Automatic power off
- ◆ Data output
- ◆ Ratchet stop
- ◆ Supplied with setting standards (except 332-001-01)

Setting standards(included)

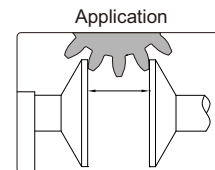
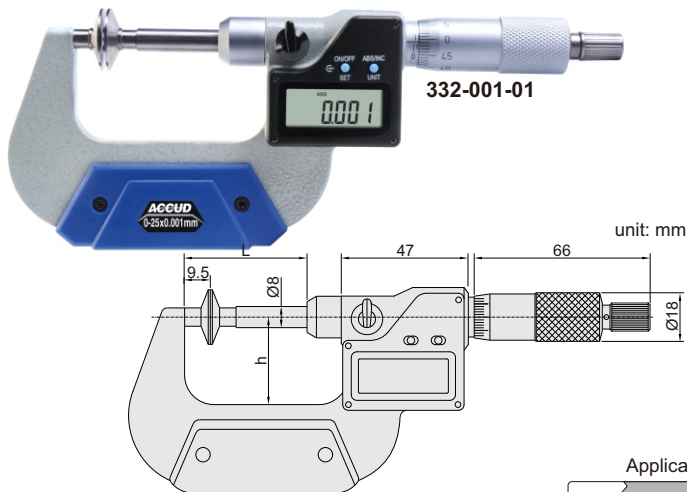

Code	Range	Accuracy	L	h	ØD	Setting standards (included)
332-001-01	0-25mm/0-1"	±4µm	43	32	20	-
332-002-01	25-50mm/1-2"	±4µm	68	44.5	20	25mm
332-003-01	50-75mm/2-3"	±5µm	93	57	20	50mm
332-004-01	75-100mm/3-4"	±5µm	118.5	70	20	75mm
332-005-01	100-125mm/4-5"	±6µm	144	82	30	100mm
332-006-01	125-150mm/5-6"	±6µm	169.5	94.5	30	125mm