

## SERIES 362

## THREE POINTS INSIDE MICROMETER

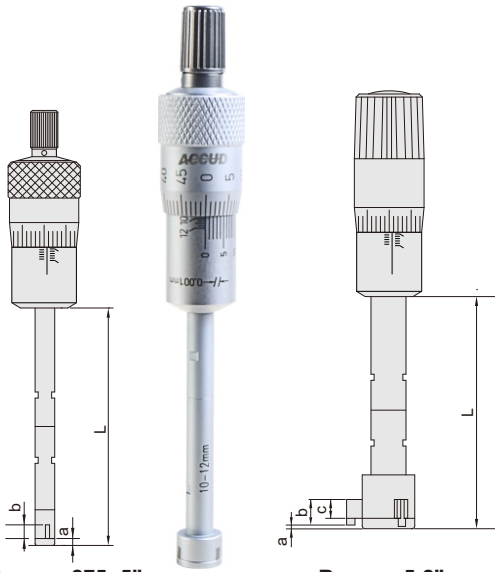

- ◆ .08-.5" graduation: .0001"
- Steel measuring faces
- .5-12" graduation: .0002"
- Carbide measuring faces
- ◆ Ratchet stop
- ◆ Extension rod are included
- ◆ Setting rings are included (Range<4")



Range .275-.5"

362-003-E01

Range .5-2"



362-008-E01

362-014-E01

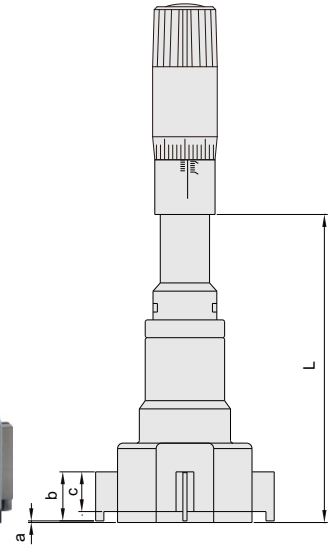

Range 2-12"

Code	Range	Accuracy	Setting ring	Extension rod	a	b	c	L
362-001-E01*	0.275-0.35"	.00015"	.275" DIA (included)	4"	.059"	.098"	/	2.146"
362-002-E01*	0.35-0.425"	.00015"	.35" DIA (included)	4"	.059"	.098"	/	2.146"
362-003-E01*	0.425-0.5"	.00015"	.5" DIA (included)	4"	.059"	.098"	/	2.146"
362-004-E01*	0.5-0.65"	.00015"	.65" DIA (included)	6"	.020"	.236"	.177"	3.150"
362-005-E01*	0.65-0.8"	.00015"	.65" DIA (included)	6"	.020"	.236"	.177"	3.150"
362-006-E01*	0.8-1"	.00015"	1" DIA (included)	6"	.020"	.315"	.236"	3.543"
362-007-E01*	1-1.2"	.00015"	1" DIA (included)	6"	.020"	.315"	.236"	3.543"
362-008-E01*	1.2-1.6"	.00015"	1.6" DIA (included)	6"	.020"	.551"	.472"	3.819"
362-009-E01*	1.6-2"	.00020"	1.6" DIA (included)	6"	.020"	.551"	.472"	3.819"
362-010-E01*	2-2.5"	.00020"	2.5" DIA (included)	6"	.020"	.689"	.571"	4.488"
362-011-E01*	2.5-3"	.00020"	2.5" DIA (included)	6"	.020"	.689"	.571"	4.488"
362-012-E01*	3-3.5"	.00020"	3.5" DIA (included)	6"	.020"	.689"	.571"	4.488"
362-013-E01*	3.5-4"	.00020"	3.5" DIA (included)	6"	.020"	.689"	.571"	4.488"
362-014-E01	4-5"	.00025"	optional	6"	.035"	1.142"	.984"	5.512"
362-015-E01	5-6"	.00025"	optional	6"	.035"	1.142"	.984"	5.512"
362-016-E01	6-7"	.00030"	optional	6"	.035"	1.142"	.984"	5.512"
362-017-E01	7-8"	.00030"	optional	6"	.035"	1.142"	.984"	5.512"
362-018-E01	8-9"	.00035"	optional	6"	.035"	1.142"	.984"	5.512"
362-019-E01	9-10"	.00035"	optional	6"	.035"	1.142"	.984"	5.512"
362-020-E01	10-11"	.00035"	optional	6"	.035"	1.142"	.984"	5.512"
362-024-E01	11-12"	.00035"	optional	6"	.035"	1.142"	.984"	5.512"

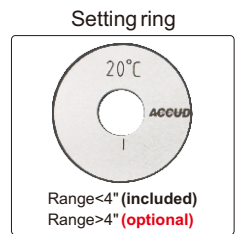

Extension rod (included)



\* With manufacturer inspection certificate