

SERIES 634

**MAGNETIC V-BLOCK
(PROFESSIONAL TYPE)**

**ATTENTION:
NOT HARDENED**

- ◆ Hold cylindrical workpiece for inspection and machining
- ◆ Hardened, high accuracy, for grinding, milling, drilling and inspection of round and square workpieces
- ◆ All working surfaces are hardened to HRC55-60°
- ◆ Top groove for large shafts
- ◆ Bottom grooves for small shafts
- ◆ Not suitable for steel or iron surfaces, otherwise the magnetic force will be reduced



634-067-01H



634-067-01HP

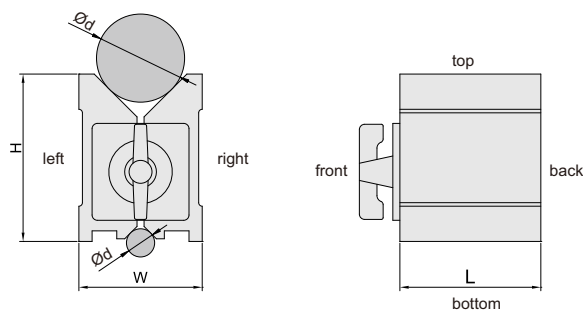
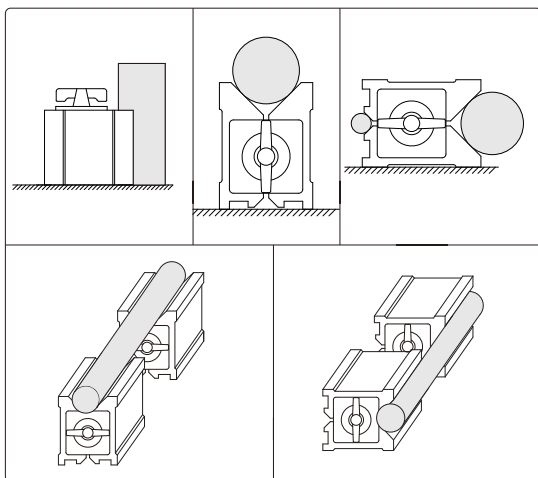

Individual

Code	Size(LxWxH)	For shaft range(Ød)	Magnetic force	V-grooves and back side squareness	Top and bottom, left and right parallelism
634-067-01H	80x70x95mm	6-67mm	64kgf	5µm	5µm
634-067-02H	100x70x95mm	6-67mm	80kgf	5µm	5µm
634-067-03H	120x70x95mm	6-67mm	96kgf	6µm	6µm

*** NEW Matched pair**

Code	Size(LxWxH)	For shaft range(Ød)	Magnetic force	V-grooves and back side squareness	Top and bottom, left and right parallelism	Height difference of a matched pair
634-067-01HP	80x70x95mm	6-67mm	64kgf	5µm	5µm	10µm
634-067-02HP	100x70x95mm	6-67mm	80kgf	5µm	5µm	10µm
634-067-03HP	120x70x95mm	6-67mm	96kgf	6µm	6µm	10µm