

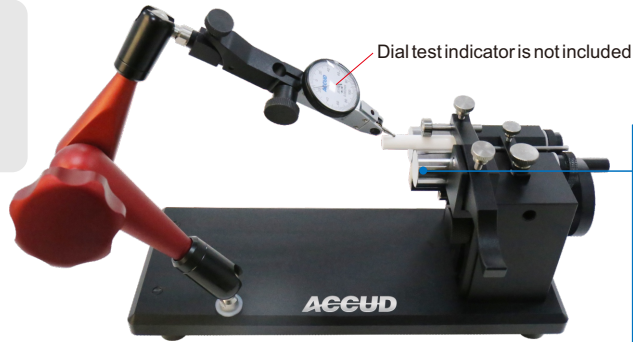

660

CONCENTRICITY GAUGE

- ◆ Optional accessories: dial test indicator (code: 261-002-01 or 261-002-02) and Mini magnetic stand (code: 286-040-01)



660-001-01

unit: mm

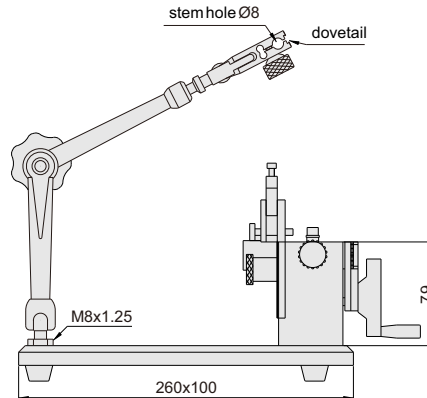
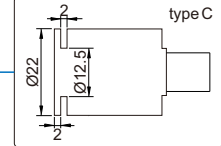
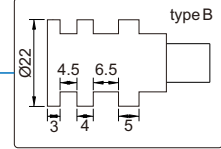
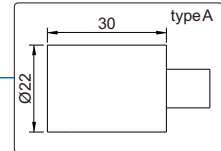

Code	Applicable diameter	Accuracy	Type
660-001-01	Ø3-35mm	0.002mm	A
660-001-02	Ø1-25mm	0.002mm	B
660-001-03	Ø1-25mm	0.002mm	C

* **NEW**

* **NEW**