

- ◆ Adjustable scale to compensate pointer wear
- ◆ Made of stainless steel

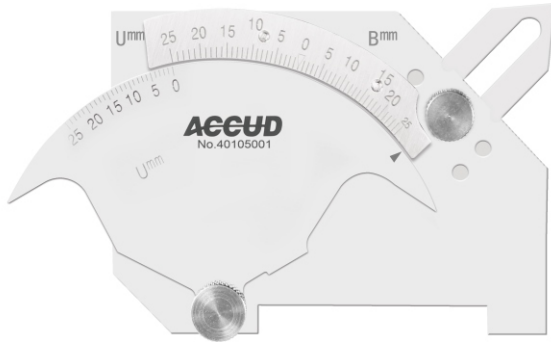

front side

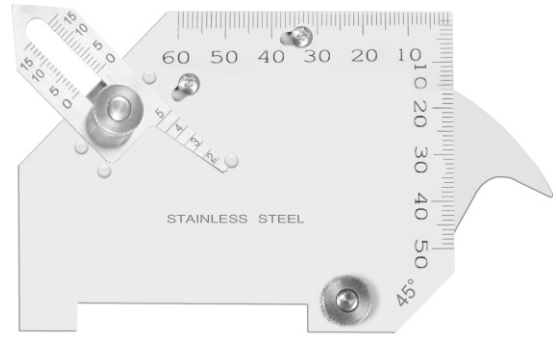

reverse side

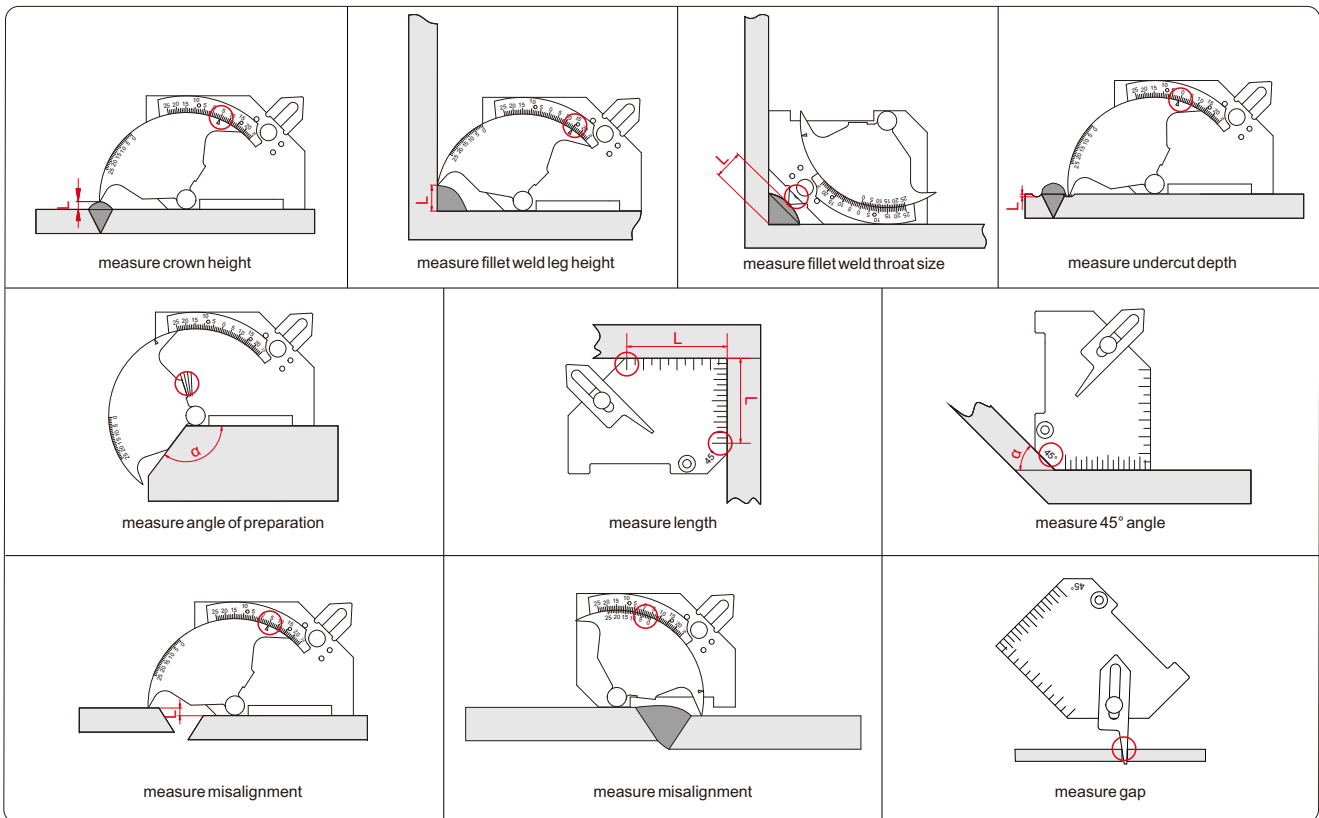

Code	Application	Range	Graduation	Accuracy
975-025-21	measure crown height	0 - 25mm	1mm	±0.5mm
	measure fillet weld leg height	0 - 25mm	1mm	±0.5mm
	measure fillet weld throat size	0 - 15mm	1mm	±0.5mm
	measure undercut depth	0 - 25mm	1mm	±0.5mm
	measure angle of preparation	0 - 60°	5°	±1°
	measure length	0 - 60mm	1mm	±0.5mm
	measure 45° angle	—	—	±1°
	measure misalignment	0 - 25mm	1mm	±0.5mm
	measure gap	2-5mm	1mm	±0.5mm

