

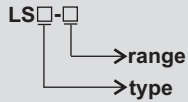

LSA1-250

◆ Code explanation:



Example:

Code	Type	Range
LSA1-50	A1	50mm
LSB5-1000	B5	1000mm

Type A1

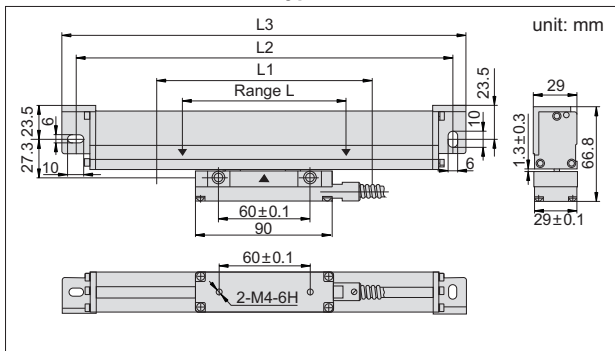

Type B5

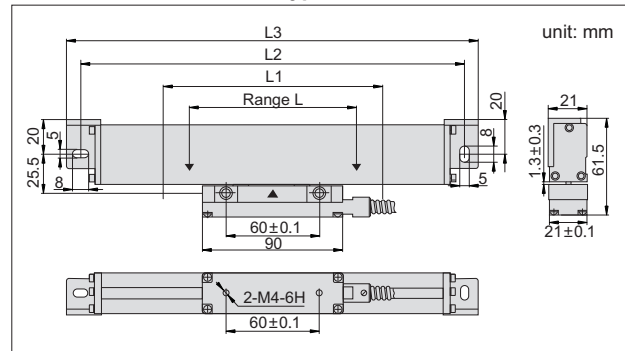

SPECIFICATION

Code	Series LSA1		Series LSB5	
	A1		B5	
Type	A1		B5	
Range	50-1000mm (step 50mm)		50-1000mm (step 50mm), 1000-3000mm(step 100mm)	
Max. travel length (L1)	L+30(L<950)	L+50(L≥950)	L+30(L<950)	L+50(L≥950)
Mounting hole pitch (L2)	L+132(L<950)	L+152(L≥950)	L+136(L<950)	L+156(L≥950)
Total length (L3)	L+149(L<950)	L+169(L≥950)	L+154(L<950)	L+174(L≥950)
Resolution	1μm		5μm	
Max. response speed	50m/min		60m/min	
Scale grating pitch	20μm			
Scale reference point pitch	50mm			
Accuracy	(5+5L/1000)μm L is the range in mm			
Cable length	3.5m (L: 50-950mm), 5m (L: 1000-1500mm), 10m (L: 1 600-3000mm)			

INCLUDED ACCESSORIES

Main unit	1pc
Shape support	1pc
Anti-dust cover	1pc
Plain base (for range >1500mm)	1pc
Mounting accessories	one package