

SERIES TTM

DIGITAL BOTTLE CAP TORQUE METER



- ◆ Test the open and tighten torque of bottle cap
- Peak, preset and real-time working mode
- ◆ Unit: N.m, N.cm, kgf.cm, lbf.cm, lbf.in
- ◆ Memory: 1000
- ◆ Power off automatically
- ◆ With software, can show the torque graph



TTM10

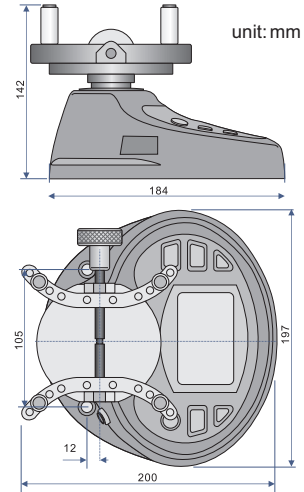

SPECIFICATION

Code	TTM2	TTM5	TTM10	TTM20
Range	0.1-2N.m	0.25-5N.m	0.5-10N.m	1-20N.m
Accuracy	±0.5%			
Resolution	0.0002N.m	0.0005N.m	0.001N.m	0.002N.m
Open size	Ø19.5-190mm			
Output	USB and RS232			
Power	rechargeable battery			
Weight	2.5kg			

INCLUDED ACCESSORIES

Main unit	1pc
Charger	1pc
Software with cable	1pc

OPTIONAL ACCESSORIES

Wireless printer	PR100
------------------	-------

